

Aspectrics MultiComponent™ 5000 Process Analyzer

- Ultra-fast – 100 scans/second
- Process rugged – industrial encoder
- Real-time data streaming – embedded Chemometrics



The Aspectrics MultiComponent 5000 process analyzer is capable of simultaneous measurement of multiple interfering gas components in the ppb range. Built on Aspectrics patented Encoded Photometric Infrared (EP-IR) technology, the Aspectrics MultiComponent 5000 Analyzer utilizes proven industrial encoder technology to deliver a stable platform for process monitoring applications such as:

- Indoor Air Monitoring
- Environmental Monitoring
- Solvent Streams

Ultra-fast Operation

The Aspectrics MultiComponent 5000 process analyzer acquires 100 scans/sec across the entire spectral range of 4000-2000 cm^{-1} . The ultra-fast scanning combined with the on-board real-time FFT processing results in:

- High sample throughput
- Real-time kinetics monitoring
- Extreme sensitivity through spectral averaging

Process Rugged Design

Aspectrics MultiComponent analyzers incorporate a pre-aligned and pre-indexed optical design to meet the requirements of the demanding process environment. The proprietary EP-IR technology does not require a Michelson Interferometer.

The results:

- Ultra-fast scanning
- Vibration insensitive operation
- No hygroscopic components
- No internal laser

MultiComponent 5000 Spectral Range

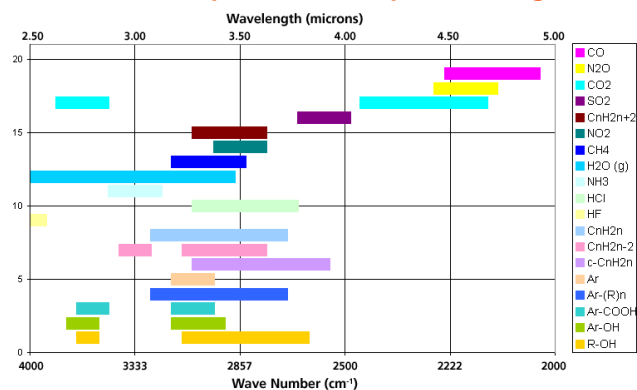

Real-Time Results

The Aspectrics MultiComponent 5000 Analyzer has an on-board PowerPC for fast, real-time data processing while the Ethernet connectivity allows access by any networked client. Aspectrics quantitative software, ChemoBuilder, enables any user to quickly and easily create multi-component PCR based calibrations and transfer them into the embedded system. Once transferred, the MultiComponent 5000 Analyzer then operates as a stand alone network analyzer.

Industry Standard Protocols

The embedded system features an OPC DA V2 compliant OPC server as well as a web server with Java™ support for external platform independent accessibility and data transfer.

Aspectrics OCX supports the MyInstrument standard and allows a user to fully integrate the Aspectrics software into their process application.

Software Tools

The Aspectrics MultiComponent 5000 Analyzer includes a suite of software to make any process integration quick and easy. These features include:

- Simultaneously control multiple instruments
- Automated, intuitive PCR-based calibration
- Remote validation and calibration augmentation for rapid system deployment

MultiComponent 5000 Specifications

- Spectral Range*: 2500-5000 nm, 4000-2000 cm^{-1}
- Wavelength Accuracy: $< 0.1 \text{ cm}^{-1}$ at 2000cm^{-1}
- Grating: Fixed holographic grating
- Resolution (128 Channel) - 128 equidistant wavelength bands. Bandwidth $< 19.7 \text{ nm}$
- RMS S/N: $> 50,000:1^{**}$
- Detector: Dual stage electronically cooled single point PbSe detector with 1 Mhz acquisition frequency (detector ADC)
- Scan Speed: 100 scans/second (100 Hz)
- Operating Range: $0-40^{\circ} \text{ C} / 32-104^{\circ} \text{ F}$

- Power consumption: $< 23 \text{ W}$
- Certification Approvals: CE, UL, CSA, TUV
- Power requirement system: 24 V DC 2.5 A
- Power supply (external): 120/240 V 50/60 Hz 1.8 A AC CE, UL, FCC, CSA, TUV approved
- System Purge: Maximum purge gas 2 bar and 5 l/min
- Dimensions (HxDxW): 333 mm (5.24 in) x 177 mm (6.99 in) x 381 mm (15 in)
- Weight: 6.8 kg (15 lbs)
- Embedded System: Power PC processor with chemometric engine, OPC DA V2 server, DCOM support and web server with Java applet
- Software: Aspectrics Command Center™ Suite
- Platform: Windows XP/2000
- Third party connectivity: MyInstrument Active X component
- Communications: Ethernet 100/10 Mbit, 2x RS-232, 25 pin Analog
- Output: TCP/IP, OPC DA v2, 25 pin Analog I/O

MultiComponent 5000 Optional Accessories

- MID-IR Development Bench: Accommodates standard third party FT-IR sample accessories for method development. Includes IR light source and optics
- Integrated Sample Cells: Aspectrics ICell low volume cells with integrated optimized source and optics
- Aspectrics Real Time Spectroscopy Software

MultiComponent 5000 Dimensions

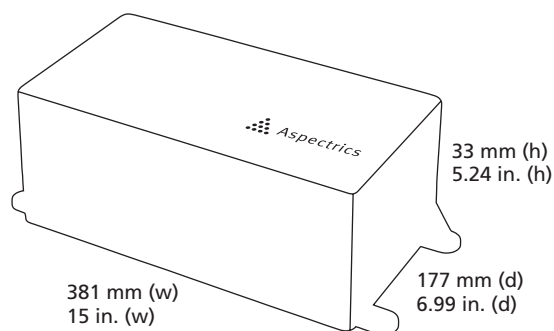

* Nominal

** Using optional MID-IR method development Bench in open beam configuration, 60s integration and maximum energy for 128 channel system.



Aspectrics

Aspectrics, Inc.
6900 Koll Center Pkwy, Suite 401
Pleasanton, CA 94566

Tel. 925.931.9270
Fax 925.931.9272

www.aspectrics.com

© Aspectrics, Inc. 6/06 U.S.A.